



- EN **WARNING** - Front seats reduce the manoeuvrability of the bicycle.
- FR **AVERTISSEMENT** - Les sièges avant réduisent la maniabilité du vélo.
- ES **ADVERTENCIA** - Los asientos delanteros reducen la maniobrabilidad de la bicicleta.
- DE **WARNUNG** - Die Manövriertfähigkeit des Lenkers könnte durch den Sitz eingeschränkt werden.
- NL **WAARSCHUWING** - Zitjes aan het stuur verminderen de wendbaarheid van de fiets.
- PT **AVISO** - Os bancos dianteiros reduzem a manobrabilidade da moto.
- IT **AVVERTENZA** - I seggiolini anteriori riducono la manovrabilità della bicicletta.
- SV **VARNING** - Frontsitsar minskar cykelns manövreringsförmåga.
- DA **ADVARSEL** - Forsæder reducerer cyklens manøvreedygtighed.
- NO **ADVARSEL** - Frontmonterte barneseter reduserer manøvrerbarheten til sykkelen.
- FI **VAROITUS** - Eteen kiinnitetty istuimet heikentävät polkupyörän ohjattavuutta.
- JA **警告** - 前乗せ用チャイルドシートは、自転車の操作性が下がることがあります

PRODIGEE ICON

Front seat

To transport
your world
safely.

Sustainable
Thinking.

Innovative
Solutions.

Our world is changing at a rate never experienced before. The cultural shift to be more thoughtful to our environment is evident every day. Central to this is the way in which we chose to travel. More people than ever are choosing carbon-neutral modes of transport to protect the world today and for tomorrow. The demand for bicycles and e-bikes is higher than ever. Prodigee creates innovative, stylish and complementary products which encourage users to use their bicycles more often and in new ways. Practical ideas and good products make life easier. We apply smart thinking at every point to bring the perfect blend of function and performance.

We are Prodigee.

We are Simply Smarter.

PRODIGEE

www.prodigee.eu

Bellelli s.r.l.

via Meucci 232 - 45021 Badia Polesine (RO) IT - info@prodigee.eu



9-15 kg



max 93 cm



Ø 21-28 cm



6 mm



EN14344:2022

www.prodigee.eu

FEATURES

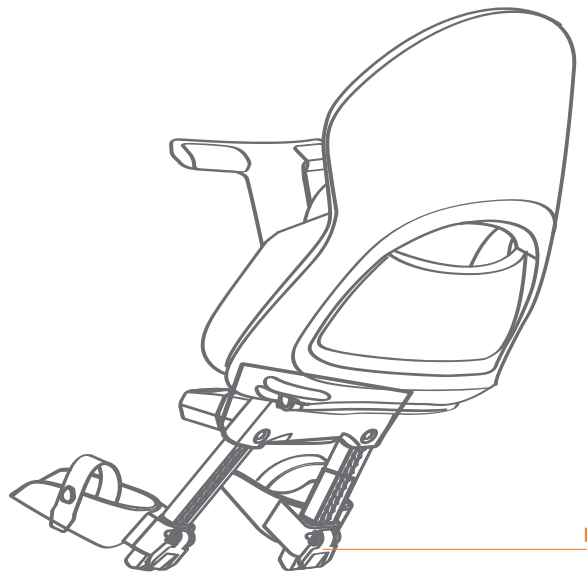
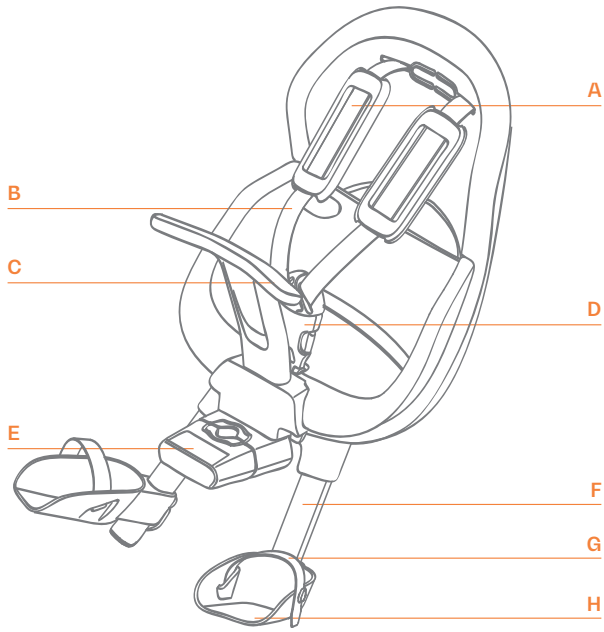

Simply Smarter.



PRODIGEE ICON

<i>User manual</i>	EN	2
<i>Manuel de l'utilisateur</i>	FR	15
<i>Manual de uso</i>	ES	28
<i>Gebrauchsanleitung</i>	DE	41
<i>Gebruikershandleiding</i>	NL	56
<i>Manual de uso</i>	PT	70
<i>Manuale d'uso</i>	IT	84
<i>Användarhandbok</i>	SV	98
<i>Brugsanvisning</i>	DA	112
<i>Brukerhåndbok</i>	NO	126
<i>Käyttöopas</i>	FI	140
使用説明書	JA	154

FEATURES

(front)

- A** Padding
- B** Safety belts
- C** Handle
- D** Buckle
- E** Fixing system
- F** Legs
- G** Foot straps
- H** Footrest

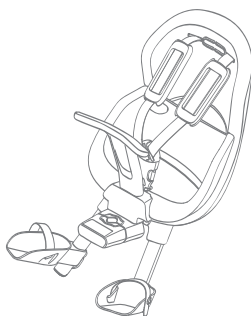

FEATURES

(back)

- I** Locking lever

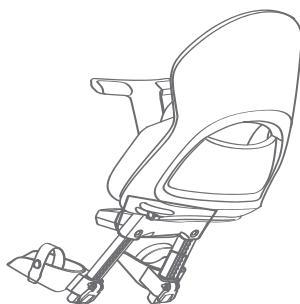



Read the instructions carefully before using the seat.

Keep them carefully for future reference.

Do not install or use the seat without having read the instructions first.

WARNINGS

- Do not modify the seat or its fixing systems.
- Do not attach anything to the seat. Attach any bags, luggage or other additional loads to the back of the bicycle. Use, for example, a pannier rack or basket attached to the back of the bicycle.
- Installing a front seat may reduce the manoeuvrability of the handlebar.
- The presence of a child in the seat affects the stability and manoeuvrability of the bicycle, especially when steering and braking.
- Never leave the bicycle parked with an unattended child in the seat.
- Do not use the seat if any parts are damaged or missing, or if any parts show signs of material wear. The presence of cracks and wear on the surface indicates that the useful life of the seat is coming to an end and that it needs to be replaced. Contact your dealer or the manufacturer for any doubts and clarifications.
- Check the temperature of the surfaces of the seat before sitting the child in it. The surfaces of a seat left in the sun may be very hot and burn the child's skin.
- If the seat can be reclined, check that the child's head is always well supported when reclining the seat.
- This seat is not suitable for use during sports activities such as mountain biking, downhill, gravel, road racing and similar.
- Check the regulations on transporting children in seats contained in the Highway Code of the country where the seat is used.
- Remove the seat from the bicycle when transporting the seat outside a vehicle (e.g. on the roof of a car, on a towed trolley or at the

back of a camper van): air turbulence may damage the seat or loosen its connections, causing an accident.

Recommended weight, height and age:



9-15 kg



max 93 cm



+9 months

- Periodically check that the child does not exceed the weight and height limits for this seat as he/she grows.
- Only transport children who are able to remain seated without help for a sufficiently long time, at least equal to the duration of the bike ride.
- Do not use the seat with children who are too young to sit safely in the seat.

SAFETY NOTES ON INSTALLATION

- Install on bicycles with 26", 28" and 29" diameter wheels.
- Only install on bicycles that can support the weight of the seat and child.
- Do not install on bicycles with lightweight aluminium or carbon fibre frames: the seat fastening systems may damage the frame.
- Before installing the seat, refer to the user manual of the bicycle or contact your dealer or the manufacturer for any doubts and clarifications.
- Do not install on mopeds, scooters, motorbikes and similar.
- Use is permitted on electrically power assisted cycles with a maximum assisted speed of 25km/h (according to EN15914 or equivalent Standards). Electric assistance must always depend on pedalling and it must be deactivated above a speed of 25 km/h.

- Refer to the user manual of the bicycle, or contact your dealer or the bicycle manufacturer.
- Do not install on bicycles driven solely by an electric motor.
 - Install the seat with the backrest slightly tilted backwards.
 - Install the seat only in the direction of travel.
 - Align the seat with the bike axle.
 - Check that all parts of the bicycle work properly after installing the seat.

SAFETY NOTES ON THE USE OF THE SEAT

- Do not install and adjust the seat with the child in it.
- Be very careful when sitting the child in the seat: the bicycle must be stable and well-balanced.
- Always use the safety belts and the foot straps.
- Check that the child is properly buckled into the seat before each trip.
- The child must wear a helmet of appropriate size and approved according to Standard EN1078:2012 + A1:2012.
- Make sure that the child cannot reach pointed or sharp parts of the bicycle, such as frayed brake cables or similar.
- Make sure that no part of the child or the child's clothing can come into contact with the moving parts of the seat and the bicycle. Repeat this check as the child grows.
- Make sure that the child's feet cannot reach the wheels of the bicycle in any way.
- Make sure that the child's fingers cannot reach the brakes of the bicycle in any way.
- Make sure that the seat belts cannot reach the wheels or other moving parts of the bicycle, even when there is no child in the seat.
- Dress the child in clothing that is warmer and more protective than the clothes worn by the cyclist.

- Make sure that the child is protected in case of rain.
- When installing and using the seat for the first time, it is advisable to take a short test ride in a quiet and safe area before venturing out into traffic.

PRELIMINARY OPERATIONS

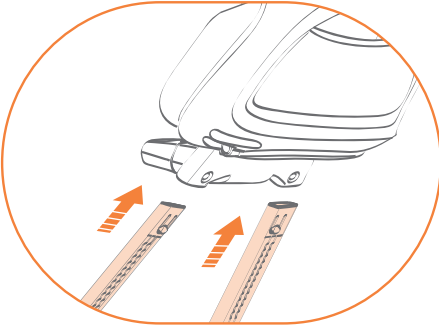

1

Slide the child's legs into the dedicated slots under the seat.

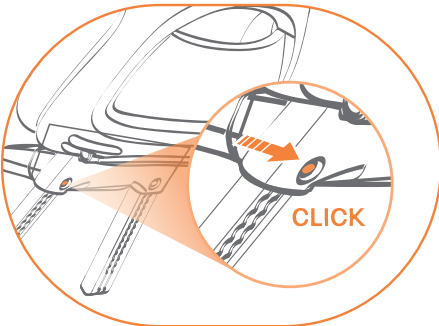

2

Having done this, make sure that the button has clicked into position.

ⓘ **Warning:** if the button has not clicked, the leg is not inserted correctly: repeat the operation.

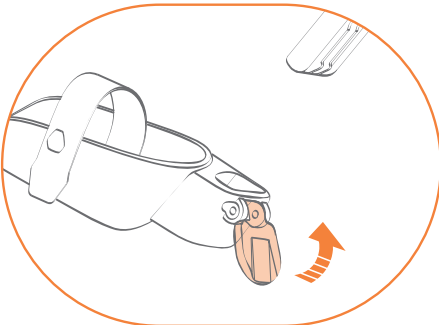

3

Take a footrest. Turn the locking lever upwards.

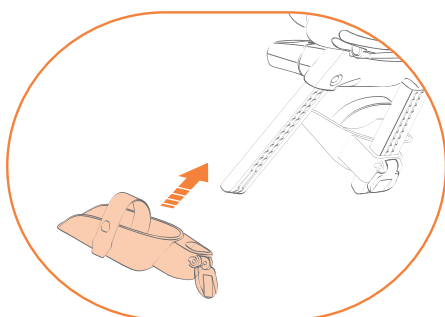

4

Slide the footrest into the leg.

The strap must be towards the inside of the seat, while its fastening hook must be towards the outside of the seat.

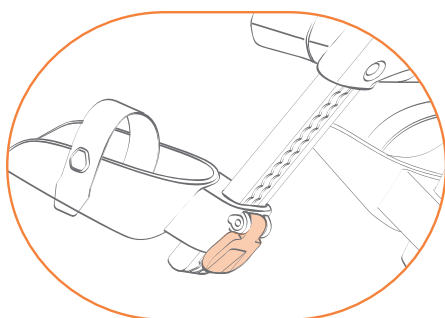

5

Push the locking lever down to close it.

Repeat the same operations on both sides.

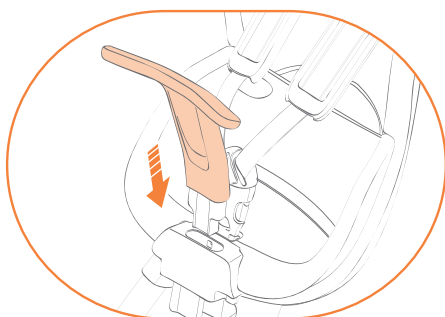

6

Insert the front handle into its seat. A click will indicate that it is correctly locked in position.

INSTALLING THE SEAT

- Do not perform the installation operations with the child in the seat.
- Identify all the components before performing the installation operations.

INSTALLING THE SUPPORT BLOCK

- Remove any baskets or bike racks if they obstruct the installation operations.
- Remove the block cover.

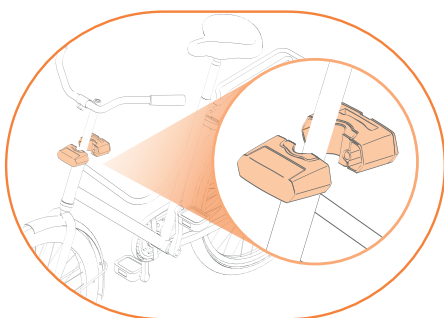

1

Install the support block around the bike frame as shown in the figure.

Check that the brake and gear cables do not interfere with the block.

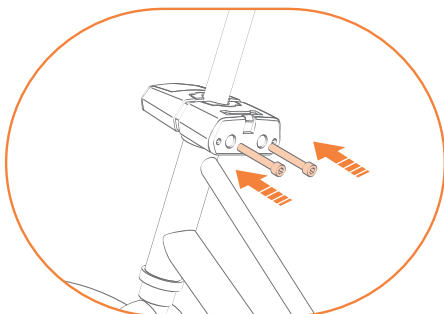

2

Insert the screws into their seats.



3

Tighten the screws of the block after finding the best position for the seat.

! **Warning:** periodically check the tightness of the screws. The fasteners may become loose with use.

INSTALLING THE SEAT ON THE BICYCLE

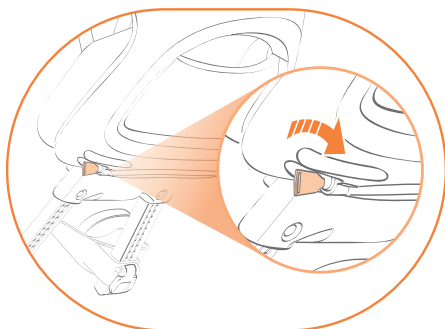

1

Turn the key clockwise to deactivate the anti-theft protection.

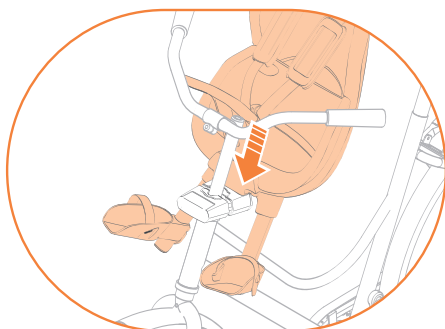

2

Insert the support fork into the slot at the top of the block.

! Warning:

Having done this, make sure that the handle has clicked back. If it has not clicked, the fork is not inserted correctly: repeat the operation.

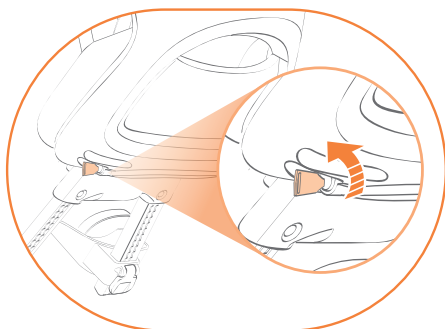

3

Turn the key counter-clockwise to activate the anti-theft protection.

USING THE SEAT

ADJUSTING THE SEAT

Adjust the height of the footrests so that the child's feet can rest fully in the footrests.

To move the footrests from one position to another:

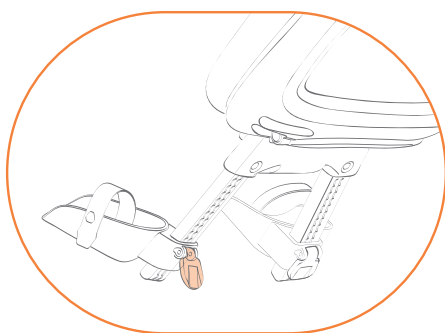

1

Turn the footrest locking lever upwards.

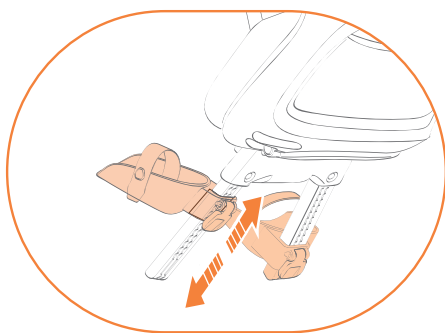

2

Slide the footrest up or down until the desired position has been reached.

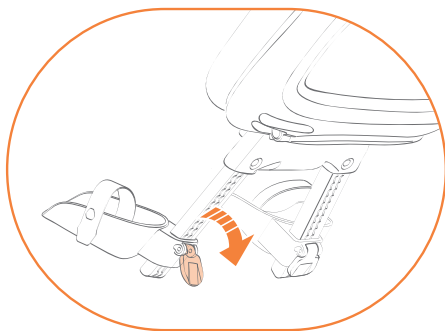

3

Push the locking lever down to close it.

Repeat the same operations on both sides.

USING THE SEAT

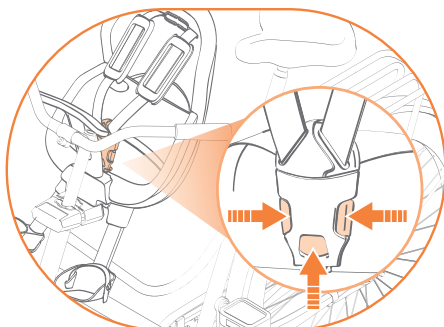

1

Press the central button and the side flaps of the buckle to open it.

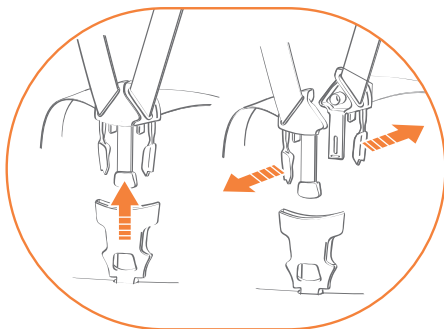

2

Move the belts away by resting them on the sides of the seat.

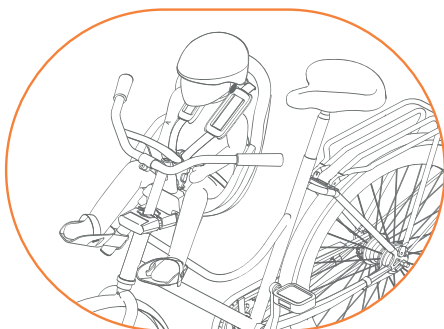

3

Sit the child in the seat.

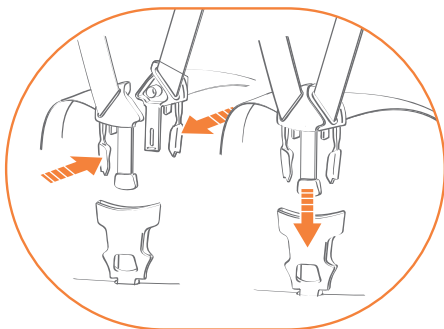

4

Join the hooks and insert them into the buckle. A **click** will indicate that they have been closed correctly.

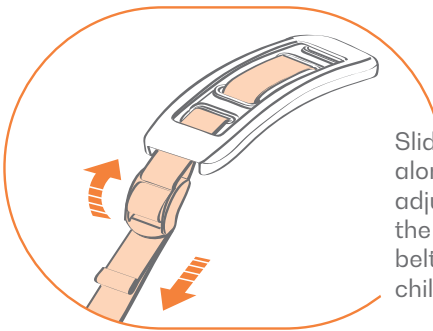

5

Slide the plastic clips along the seat belt to adjust its length; adjust the length of the seat belt so that it holds the child in the seat tightly.

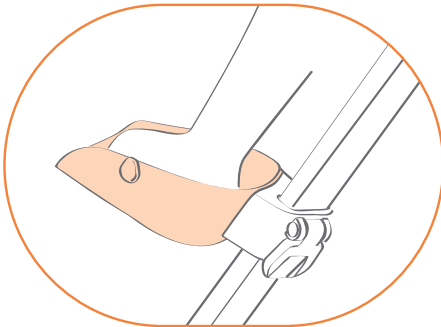

6

Place the child's feet in the footrests.

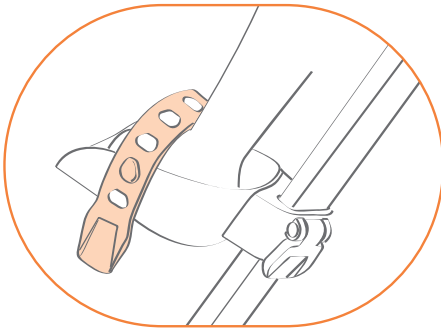

7

Tighten the foot strap by hooking it onto the pin on the side of the footrest.

Repeat the same operation for both footrests.

HOW TO REMOVE THE CHILD

- Release the foot straps.
- Press the central button and the side flaps of the buckle to open it.
- Move the belts away from the child's body.
- Lift the child out of the seat.

HOW TO REMOVE THE SEAT FROM THE BICYCLE

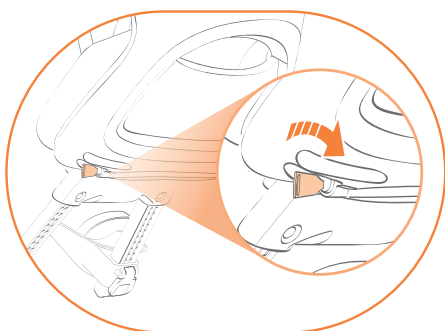

1

Turn the key clockwise to deactivate the anti-theft system.

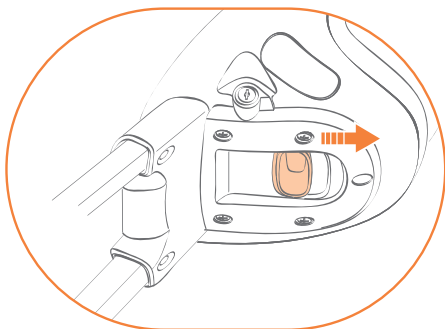

2

Pull the lever under the seat and remove the support fork from the block by pulling the seat upwards.

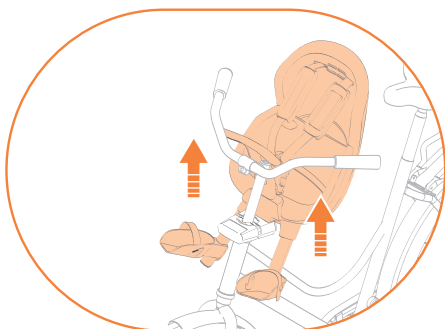

3

Raise up the seat.

MAINTENANCE

Periodically clean the seat with soap and water.

Do not use aggressive detergents.