



EN **WARNING** - For safety reasons this seat shall only be fitted to luggage carriers conforming to EN ISO 11243:2016 marked with a 27 kg load.

FR **AVERTISSEMENT** - Pour des raisons de sécurité, ce siège ne doit être installé que sur des supports à bagages conformes à la norme EN ISO 11243:2016 marqués d'une charge de 27 kg.

ES **ADVERTENCIA** - Por razones de seguridad, este asiento sólo debe instalarse en portaequipajes conformes con la norma EN ISO 11243:2016 marcado con una carga de 27 kg.

DE **WARNUNG** - Aus Sicherheitsgründen darf dieser Kindersitz nur auf Gepäckträgern montiert werden, die der Norm EN ISO 11243:2016 entsprechen und für eine Belastung von 27 kg gekennzeichnet sind.

NL **WAARSCHUWING** - Om veiligheidsredenen mag dit stoeltje alleen worden gemonteerd op bagagedragers die voldoen aan EN ISO 11243:2016 gemarkeerd met een belasting van 27 kg.

PT **AVISO** - Por razões de segurança, este assento só deve ser instalado em porta-bagagens em conformidade com EN ISO 11243:2016 marcado com uma carga de 27 kg.

IT **AVVERTENZA** - Per ragioni di sicurezza, questo seggiolino può essere installato su portapacchi omologati secondo la EN ISO 11243:2016 e con portata 27 kg.

SV **VARNING** - Av säkerhetsskäl får denna sits endast monteras på pakethållare som överensstämmer med SS-ENISO 11243:2016 och märkts med 27 kg belastning.

DA **ADVARSEL** - Af sikkerhedsmæssige årsager må denne barnestol kun monteres på bagagebærere i overensstemmelse med EN ISO 11243:2016 mærket med en belastning på 27 kg.

NO **ADVARSEL** - Av sikkerhetshensyn må dette barnesetet kun monteres på bagasjebrett som samsvarer med EN ISO 11243:2016 merket med 27 kg last.

FI **VAROITUS** - Turvallisuussyistä tämä istuin tulee kiinnittää vain tavaratelineisiin, jotka vastaavat standardia EN ISO 11243:2016 ja joissa on merkintä 27 kg:n kuormasta.

JA **警告** - 安全のため、このチャイルドシートは、必ず、規格 EN ISO 11243:2016 に準拠している耐荷重が 27 kg のキャリアに固定してください

PRODIGEE ICON

Rear seat
Bike rack mounting



9-22 kg



max 110 cm



11-19 cm



Ø 8-20 mm



6 mm

PRODIGEE

www.prodigee.eu

Bellelli s.r.l.

via Meucci 232 - 45021 Badia Polesine (RO) IT - info@prodigee.eu



EN14344:2022

www.prodigee.eu

To transport your world safely.

Sustainable Thinking.

Innovative Solutions.

Our world is changing at a rate never experienced before.

The cultural shift to be more thoughtful to our environment is evident every day. Central to this is the way in which we chose to travel. More people than ever are choosing carbon-neutral modes of transport to protect the world today and for tomorrow. The demand for bicycles and e-bikes is higher than ever.

Prodigee creates innovative, stylish and complementary products which encourage users to use their bicycles more often and in new ways.

Practical ideas and good products make life easier. We apply smart thinking at every point to bring the perfect blend of function and performance.

We are Prodigee.

We are Simply Smarter.

FEATURES

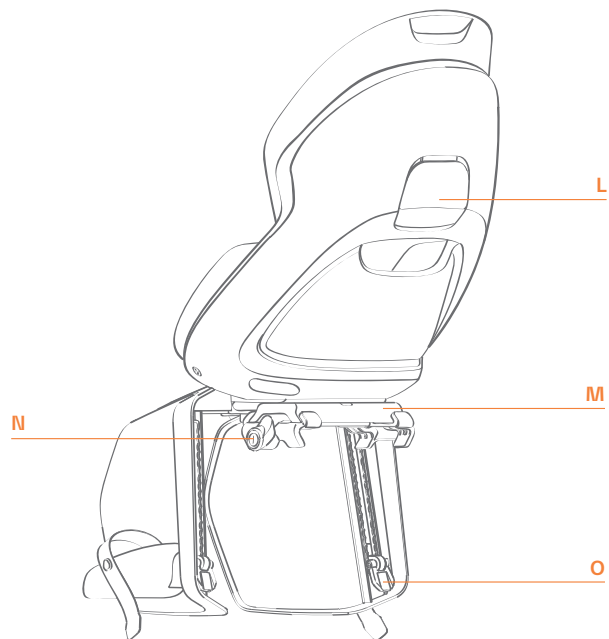
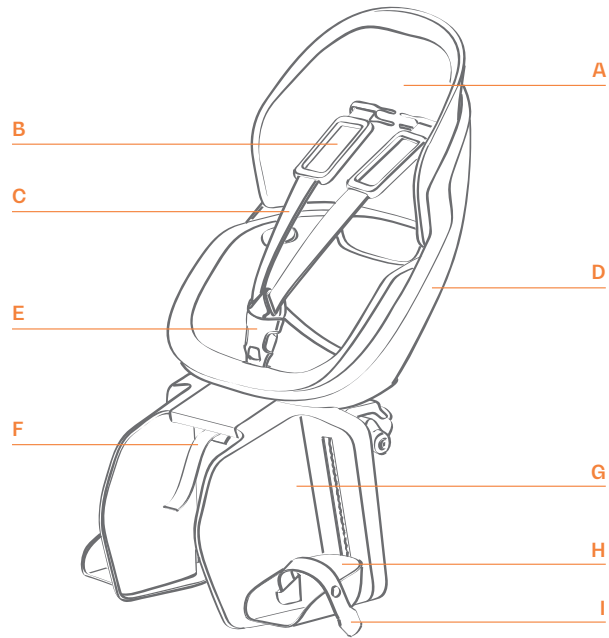

Simply Smarter.



PRODIGEE ICON

<i>User manual</i>	EN	2
<i>Manuel de l'utilisateur</i>	FR	16
<i>Manual de uso</i>	ES	30
<i>Gebrauchsanleitung</i>	DE	44
<i>Gebruikershandleiding</i>	NL	59
<i>Manual de uso</i>	PT	74
<i>Manuale d'uso</i>	IT	89
<i>Användarhandbok</i>	SV	104
<i>Brugsanvisning</i>	DA	119
<i>Brukerhåndbok</i>	NO	134
<i>Käyttöopas</i>	FI	149
使用説明書	JA	164

FEATURES

(front)

- A** Headrest
- B** Padding
- C** Safety belts
- D** Backrest
- E** Buckle
- F** Additional safety belt
- G** Legs
- H** Footrest
- I** Foot straps

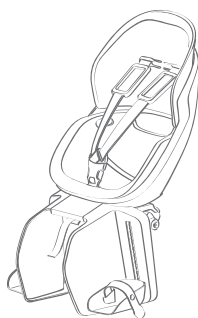

FEATURES

(back)

- L** Headrest adjustment handle
- M** Fixing system
- N** Key
- O** Locking lever

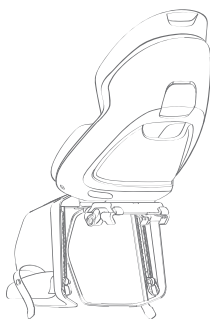



Read the instructions carefully before using the seat. Keep them carefully for future reference. Do not install or use the seat without having read the instructions first.

WARNINGS

- Do not modify the seat or its fixing systems.
- Do not attach anything to the seat. Attach any bags, luggage or other additional loads to the front of the bicycle. Use, for example, a pannier rack or basket attached to the front of the bicycle.
- The presence of a child in the seat affects the stability and manoeuvrability of the bicycle, especially when steering and braking.
- Never leave the bicycle parked with an unattended child in the seat.
- Do not use the seat if any parts are damaged or missing, or if any parts show signs of material wear. The presence of cracks and wear on the surface indicates that the useful life of the seat is coming to an end and that it needs to be replaced. Contact your dealer or the manufacturer for any doubts and clarifications.
- Check the temperature of the surfaces of the seat before sitting the child in it. The surfaces of a seat left in the sun may be very hot and burn the child's skin.
- If the seat can be reclined, check that the child's head is always well supported when reclining the seat.
- This seat is not suitable for use during sports activities such as mountain biking, downhill, gravel, road racing and similar.
- Check the regulations on transporting children on bicycles contained in the Highway Code of the country where the seat is used.
- Remove the seat from the bicycle when transporting the seat outside a vehicle (e.g. on the roof of a car, on a towed trolley or at the back of a camper van): air turbulence may damage the seat or loosen its connections, causing an accident.

Recommended weight, height and age:



9-22 kg



max 110 cm



+12 months

- Periodically check that the child does not exceed the weight and height limits for this seat as he/she grows.
- Only transport children who are able to remain seated without help for a sufficiently long time, at least equal to the duration of the bike ride.
- Do not use the seat with children who are too young to sit safely in the seat.

SAFETY NOTES ON INSTALLATION

- Install on bicycles with 26", 28" and 29" diameter wheels.
- Only install on bicycles that can support the weight of the seat and child.
- Do not install on bicycles with lightweight aluminium or carbon fibre frames: the seat fastening systems may damage the frame.
- Before installing the seat, refer to the user manual of the bicycle or contact your dealer or the manufacturer for any doubts and clarifications.
- Do not install on mopeds, scooters, motorbikes and similar.
- Use is permitted on electrically power assisted cycles with a maximum assisted speed of 25km/h (according to EN15914 or equivalent Standards). Electric assistance must always depend on pedalling and it must be deactivated above a speed of 25 km/h. Refer to the user manual of the bicycle, or contact your dealer or the bicycle manufacturer.
- Do not install on bicycles driven solely by an electric motor.
- Install the seat so that 2/3 of its depth or its centre of gravity is between the front and rear bike axle: risk of overturning.

- Install the seat with the backrest slightly tilted backwards.
- Install the seat as close as possible to the saddle.
- Install the seat only in the direction of travel.
- Align the seat with the bike axle.
- Check that all parts of the bicycle work properly after installing the seat.

SAFETY NOTES FOR INSTALLATION ON PANNIER RACKS

- Install the seat on pannier racks between 11 cm and 19 cm wide.
- Install the seat on pannier racks whose frame is made of tubes with a diameter between 8 mm and 20 mm.
- Do not install on pannier racks with an irregular or asymmetrical shape.
- Only use with pannier racks with a load capacity of 27 kg and approved according to Standard EN ISO 11243:2016.
- Do not exceed the rated load capacity of the pannier rack.

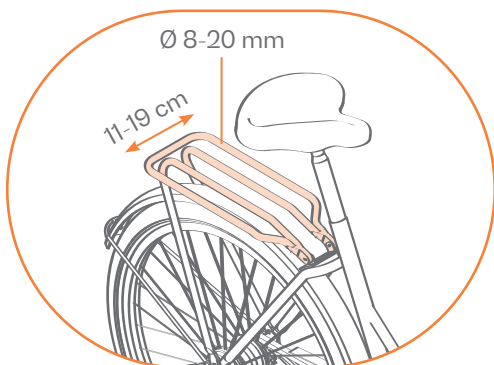

⚠ Warning:

- The total weight of the seat with the child in it must be less than the maximum capacity of the pannier rack.

- Always attach the additional safety belt to the bicycle frame.
- Before each use, check that the additional safety belt is correctly attached to the bicycle frame.

SAFETY NOTES ON THE USE OF THE SEAT

- Do not install and adjust the seat with the child in it.
- Be very careful when sitting the child in the seat: the bicycle must be stable and well-balanced.
- Always use the safety belts and the foot straps.
- Check that the child is properly buckled into the seat before each trip.
- The child must wear a helmet of appropriate size and approved according to Standard EN1078:2012 + A1:2012.
- Make sure that the child cannot reach pointed or sharp parts of the bicycle, such as frayed brake cables or similar.
- Make sure that no part of the child or the child's clothing can come into contact with the moving parts of the seat and the bicycle. Repeat this check as the child grows.
- Make sure that the child's feet cannot reach the wheels of the bicycle in any way.
- Make sure that the child's fingers cannot reach the brakes of the bicycle in any way.
- Make sure that the child's fingers cannot reach the springs under the saddle in any way. Use a saddle cover to cover the springs.
- Make sure that the seat belts cannot reach the wheels or other moving parts of the bicycle, even when there is no child in the seat.
- Dress the child in clothing that is warmer and more protective than the clothes worn by the cyclist.
- Make sure that the child is protected in case of rain.
- When installing and using the seat for the first time, it is advisable to take a short test ride in a quiet and safe area before venturing out into traffic.

PRELIMINARY OPERATIONS

Install the legs as shown in the pictures.

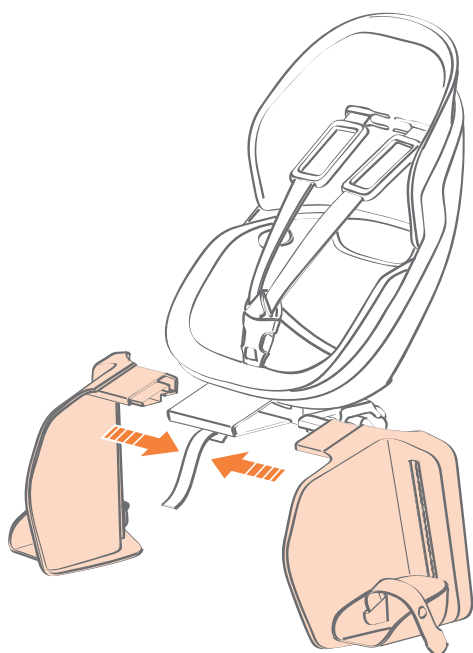

⚠ Warning:

once inserted, check that the locking button under the seat has clicked into place correctly. If it has not clicked, it means that the legs are not installed correctly: repeat the installation operation.

INSTALLING THE SEAT

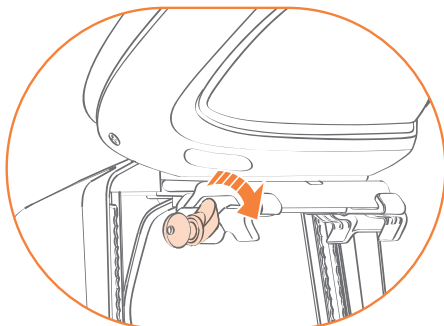

1

Turn the key clockwise to deactivate the anti-theft protection.

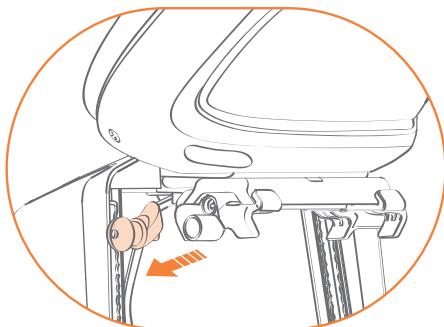

2

Remove the anti-theft protection.

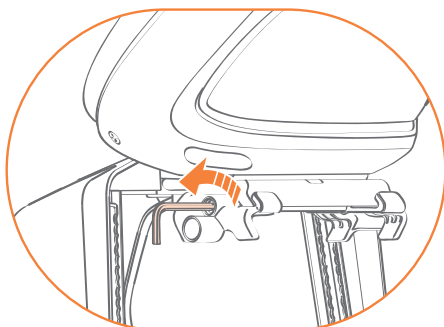

3

Turn the threaded bar counter-clockwise to open the jaws. Use a 6 mm hex wrench.

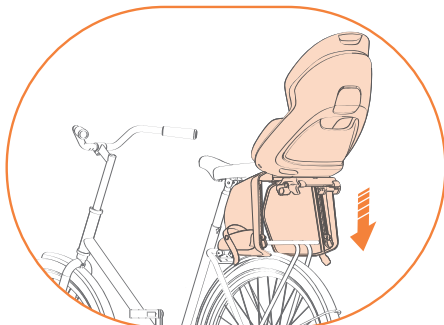

4

Place the seat on the pannier rack.

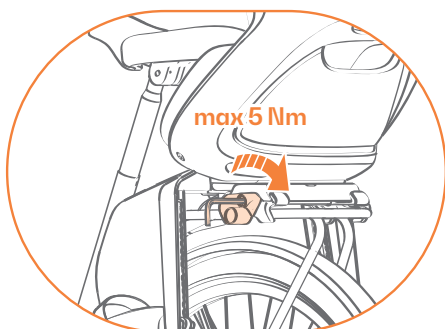

5

Turn the threaded bar clockwise to tighten the jaws. Use a 6 mm hex wrench.

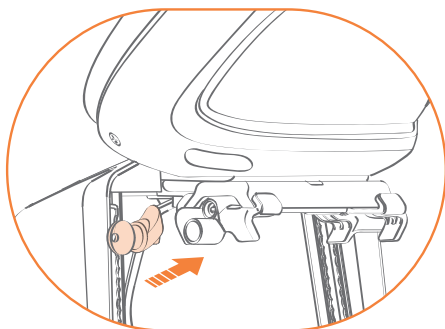

6

Activate the anti-theft protection.

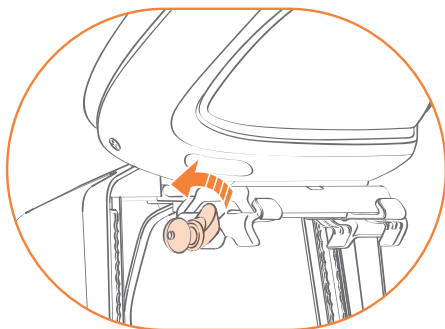

7

Turn the key counter-clockwise to activate the anti-theft protection.

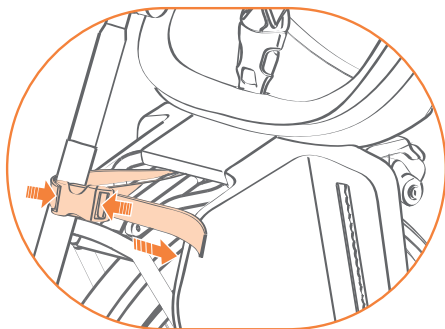

8

Attach the safety belt to the bicycle frame.

USING THE SEAT

Adjust the height of the headrest, of the safety belts and of the footrests before using the seat.

Adjusting the height of the headrest and of the safety belts.

Adjust the height of the headrest so that the child's head is well-supported; the headrest must not touch the child's shoulders.

Position the safety belts just above the child's shoulders.

To move the headrest and the safety belts from one position to another:

- Pull the handle located behind the backrest outwards and, at the same time, move the headrest up or down until the desired position has been reached.
- Release the handle located behind the backrest.
- Check that the headrest is correctly secured in the desired position by trying to move it up or down.
- A click will indicate that it is correctly locked in position.

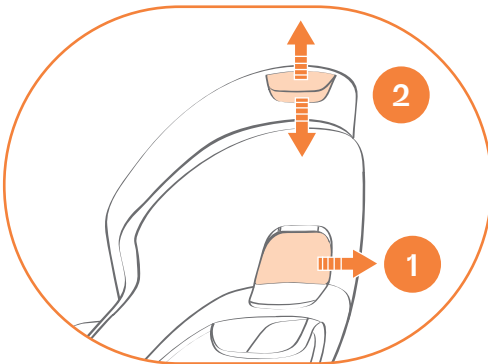

Adjusting the footrests.

Adjust the height of the footrests so that the child's feet can rest fully in the footrests.

To move the footrests from one position to another:

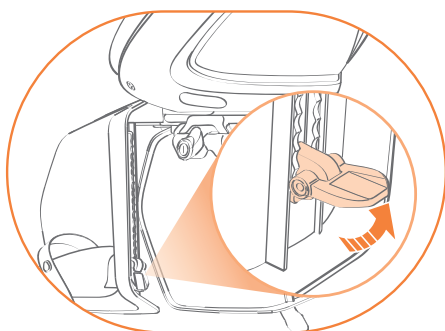

1

Turn the footrest locking lever upwards.

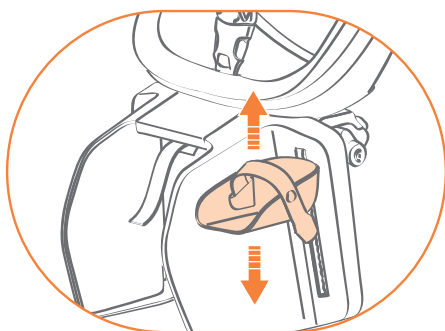

2

Slide the footrest up or down until the desired position has been reached.

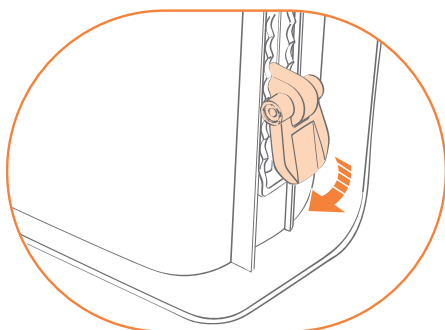

3

Push the locking lever down to close it.

Repeat the same operations on both sides.

USING THE SEAT

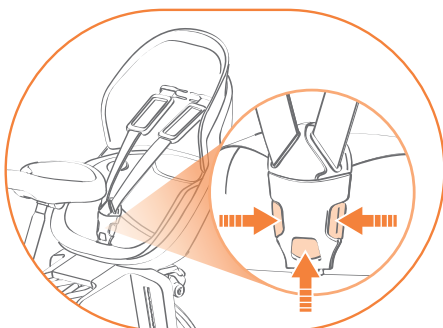

1

Press the central button and the side flaps of the buckle to open it.

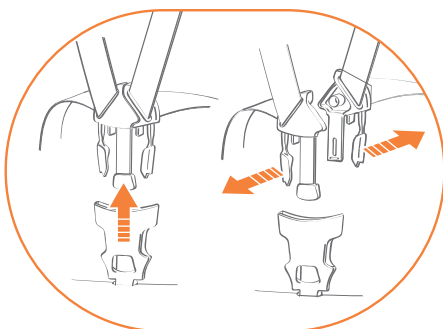

2

Move the belts away by resting them on the sides of the seat.

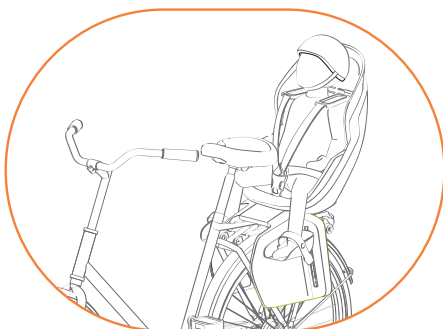

3

Sit the child in the seat.

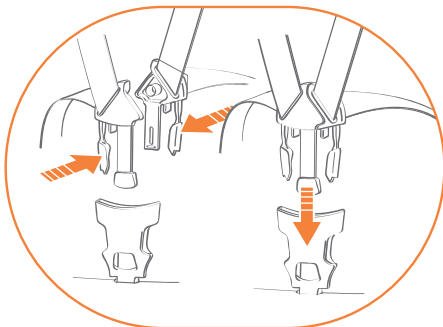

4

Join the hooks and insert them into the buckle. A **click** will indicate that they have been closed correctly.

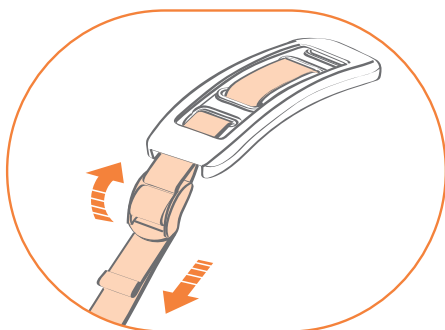

5

Slide the plastic clips along the seat belt to adjust its length; adjust the length of the seat belt so that it holds the child in the seat tightly.

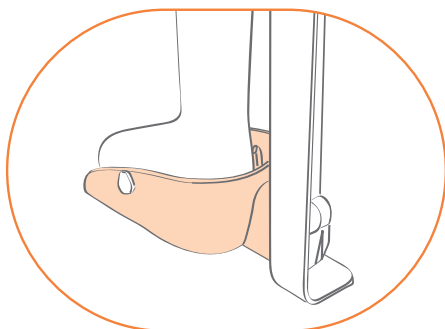

6

Place the child's feet in the footrests.

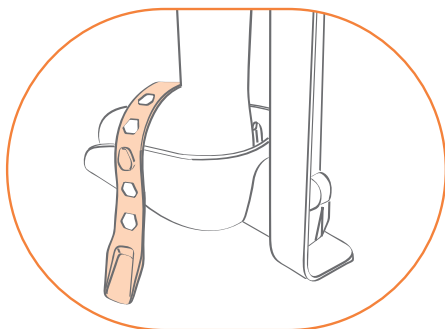

7

Tighten the foot strap by hooking it onto the pin on the side of the footrest.

Repeat the same operation for both footrests.

HOW TO REMOVE THE CHILD

- Release the foot straps.
- Press the central button and the side flaps of the buckle to open it.
- Move the belts away from the child's body.
- Lift the child out of the seat.

HOW TO REMOVE THE SEAT FROM THE BICYCLE

- Detach the safety belt from the bicycle frame.
- Turn the key clockwise to deactivate the anti-theft protection.
- Remove the anti-theft protection.
- Turn the threaded bar counter-clockwise to open the jaws. Use a 6 mm hex wrench.
- Lift the seat off the pannier rack.
- Reactivate the anti-theft protection.
- Turn the key counter-clockwise to activate the anti-theft protection.

MAINTENANCE

Periodically clean the seat with soap and water.

Do not use aggressive detergents.